

## OPERATING PRINCIPLE

The operating principle of SELF-CENTERING CHUCKS with 6 BALANCED JAWS is made of 3 pairs, and each pair has an internal link which allows them to balance in sets of two: this operating principle generates 6 FORCES which pull towards the center of the chuck.

**This does not alter the roundness of the component.**

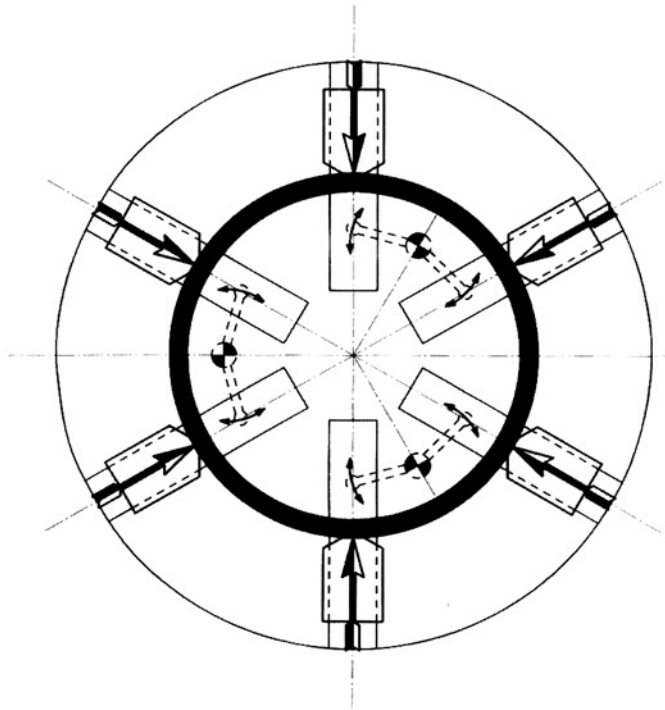
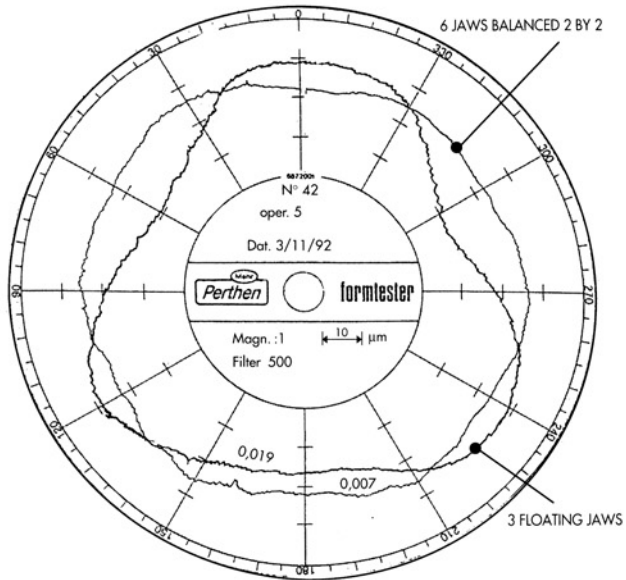

The traditional operating principle of the SELF-CENTERING CHUCK with 3 wrap-around floating jaws generates 3 radial forces which in turn generate 6 PARALLEL FORCES that do not go through the center of the chuck.

This method of clamping alters the roundness of the component determining a **3 lobes-shape**.

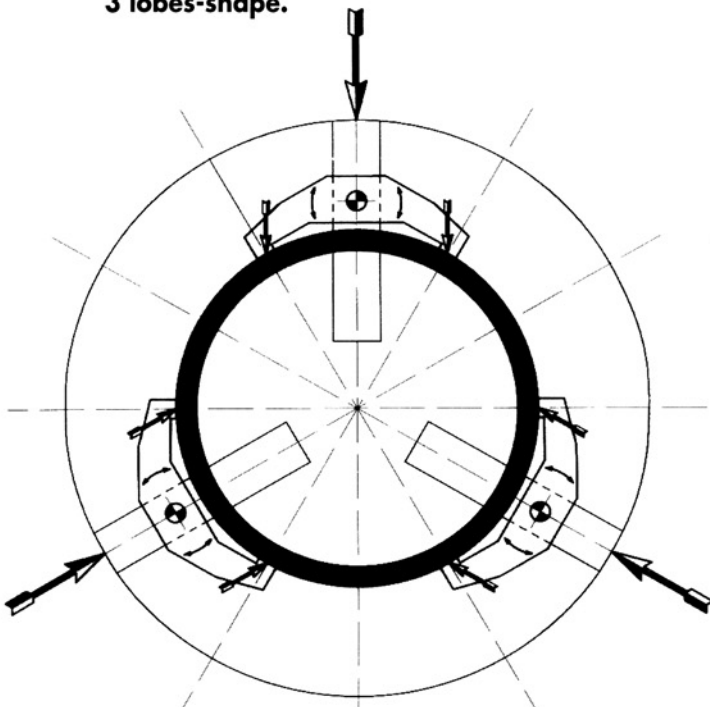

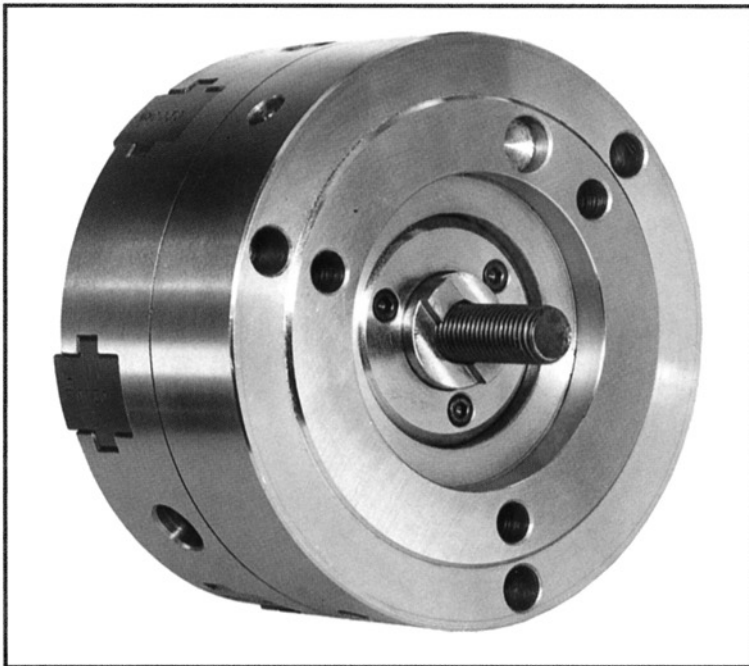
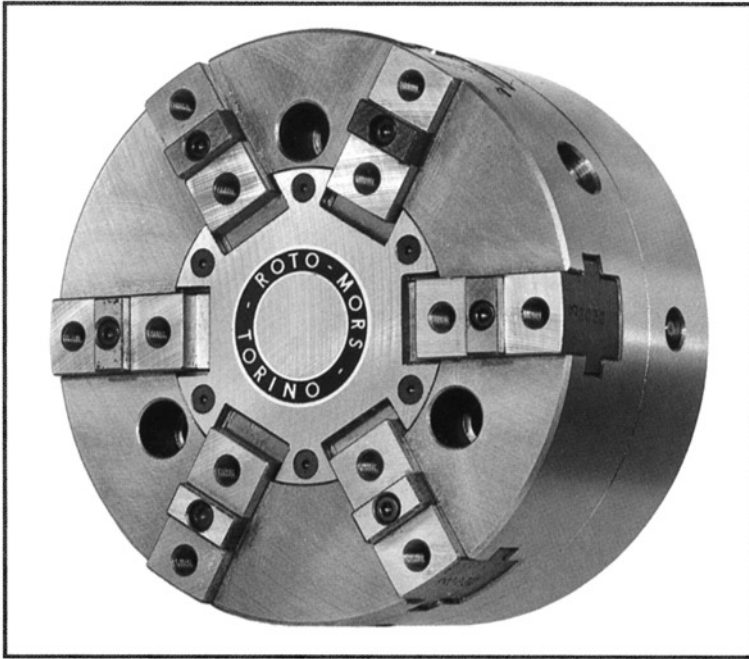

### AUTOMATIC SELF-CENTERING CHUCKS TYPE NR-P6 WITH 6 JAWS BALANCED BY 2+2+2

The self-centering chucks is equipped with a central bush which carries the 3 links at 120°; each link controls 2 levers which operate the master jaws. This determines a self-centering compensated clamping on 6 points ( 2+2+2 ) with the **radial clamping forces** pulling towards the center of the chuck. The central bush is operated by a draw-bar controlled by a single piston - hydraulic cylinder. Should it be necessary to stiffen the system during the finishing operation, in order to have a simultaneous 6 jaws self-centering action, there is a way of **removing the floating action of the 3 links**: this can be done manually by means of 3 screws, or automatically.

**AUTOMATIC SELF-CENTERING CHUCKS NR-P6 WITH 6 JAWS BALANCED BY 2+2+2 - BODY IN STEEL**

DIAMETER	160	203	250	315	350	400	500	6,00	700
JAWS STROKE mm	6	8	8	10	10	10	15	15	15
SWINGING STROKE mm	1+1	1+1	2+2	2+2	2+2	2+2	2+2	2+2	2+2
MAX. ROUNDS WITH MAX. FORCE	4000	3500	3000	2500	2000	1500	1200	1000	800
PD <sup>2</sup> Kg	0,18	0,3	0,8	2,6	5,3	9,5	13,5	24,5	28,5
MIN. FORCE ON THE DRAW-BAR Kg	300	300	300	600	600	900	900	900	900
MAX. FORCE ON THE DRAW-BAR Kg	1500	2700	2100	4200	4200	6000	6000	6000	6000
MIN. FORCE PER JAW Kg	100	100	100	200	200	300	300	300	300
MAX. FORCE PER JAW Kg	500	700	700	1400	1400	2000	2000	2000	2000
MOUNTING ASA-DIN-CAM-LOCK	5"	5"-6"	6"-8"	6"-8"	8"-11"	8"-11"	11"-15"	11"-15"	11"-15"
WEIGHT Kg	13	20	28	65	85	120	150	190	250
<b>HYDRAULIC CYLINDERS</b>									
PISTON SURFACE	40 cm <sup>2</sup>			100 cm <sup>2</sup>			100cm <sup>2</sup>		
MAX. PRESSURE	60 BAR			45 BAR			70 BAR		
TYPE	5" STROKE 20			7" STROKE 30			7" STROKE 30		